

The Model "PMF" fan unit is an intake, recirculating, and mixing fan all in one easy to install unit. Provides economical makeup air for many applications. This unit is well suited for **GREENHOUSE, AGRICULTURAL AND INDUSTRIAL BUILDINGS.**

Features

- One piece polyethylene corrosion resistant housing, incorporates fan unit, motorized intake shutters and optional inside recirculating shutters.
- Energy-efficient variable speed direct drive motor.
- Polypropylene fan blade with cast aluminum hub for corrosion resistance and high efficiency.
- Unique design allows easy installation with all components in one package.
- Polytube mounts easily on unit. With polytube attached, this unit will distribute heat or move stratified air throughout building.

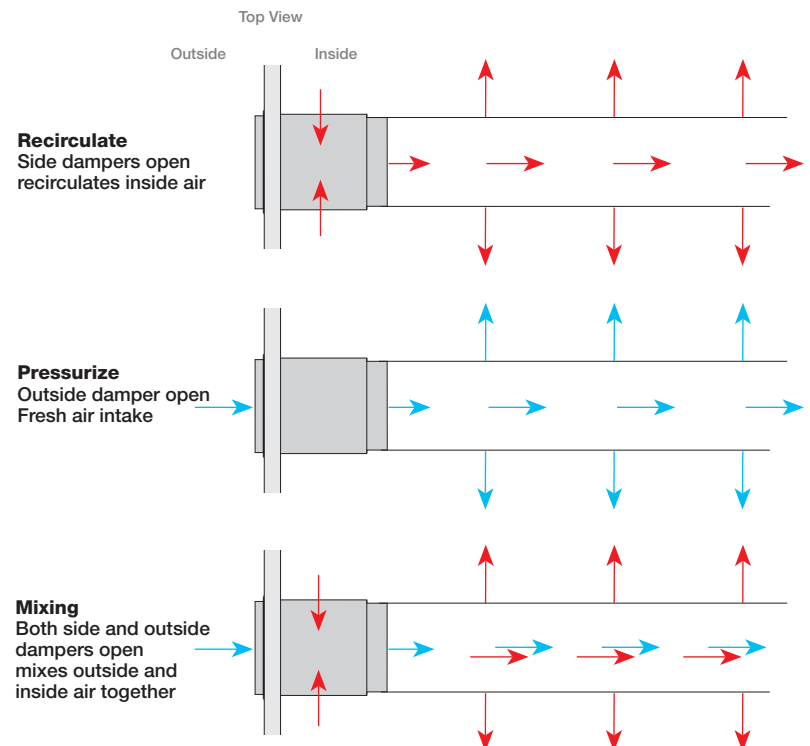
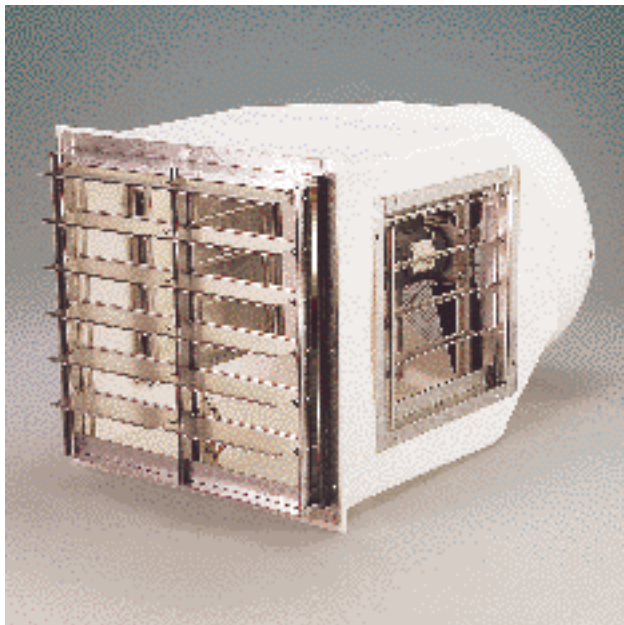

Dimensional Data:

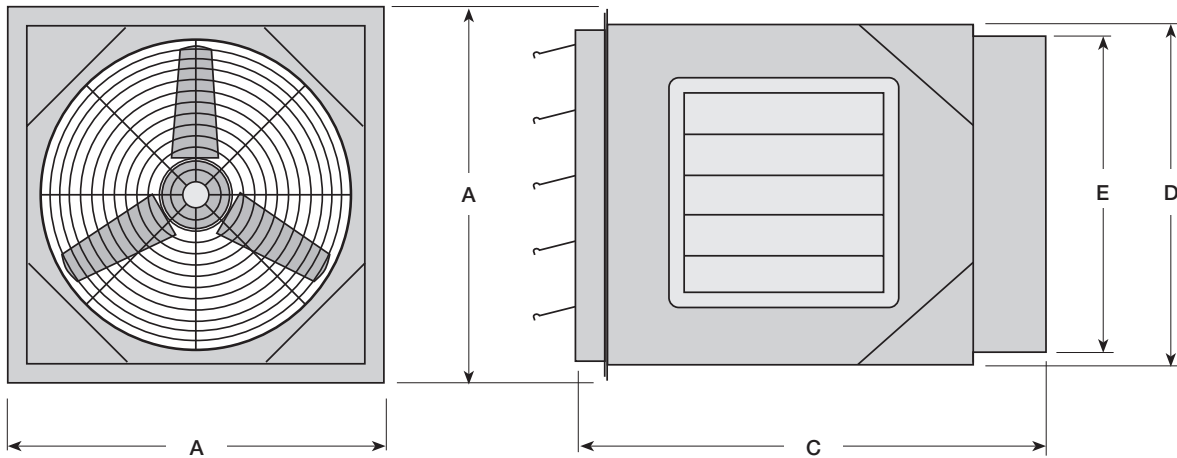

MODEL	BLADE DIA.	A	B	C	D
PMF	30"	36"	31"	48"	33"

Performance Data (cfm):

MODEL	HP	RPM	.0" SP	.100" SP	.125" SP	.150" SP
PMF	1/2	850	9545	8761	8476	8115

Installation Details:

LOCATION:

Mount unit as high in building as possible to move stratified air in ceiling areas.

WIRING:

Wiring should be done in accordance with local electrical codes that apply.

Due to continuing research, Future Products Corporation reserves the right to change specifications without notice.