



The model "GBF" is an exhaust or circulation fan unit. Ideally suited for use in POULTRY, GREENHOUSE, INDUSTRIAL AND OTHER AGRICULTURAL FACILITIES.

Features

- 36" and 48" direct drive fan requiring no belts, and no bearings to grease. High efficiency with no drive loss.
- All galvanized construction for years of corrosion resistance.
- Galvanized steel motor mount and fan blade precisely balanced with 2 set screws for safety.
- Energy efficient, totally enclosed heavy duty motor with ball bearings and overload protection.
- Model GBF can be used for exhaust or circulating ventilation.
- Optional shutter can mount to outside of frame for weather resistance.

Performance Data (cfm):

MODEL	BLADE DIA.	HP	RPM	VOLTS	0" SP	.10" SP	.20" SP
GBF-36	36"	1/2	850	115/230	10765	10340	9875
GBF-48	48"	1	850	230	20,600	20,000	19,580

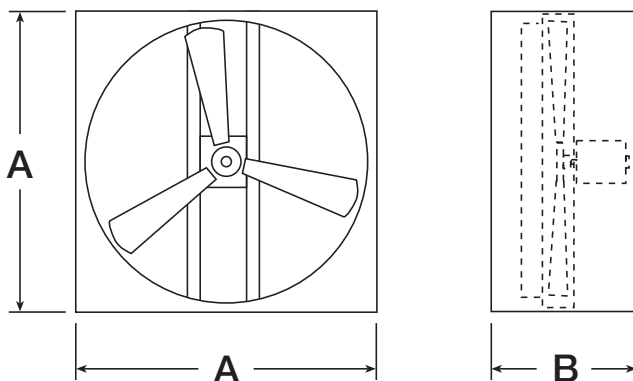

Dimensional Data:

MODEL	A	B	WT.
GBF-36	39"	15	84#
GBF-48	52"	16	155#

Due to continuing research, Future Products reserves the right to change specifications without notice.

Future Products • 22 Park View Circle • Mosinee, WI 54455
 Phone 715-693-4444 • Toll Free 877-FP4-FANS • Fax 715-693-4480

www.FP4-FANS.com