

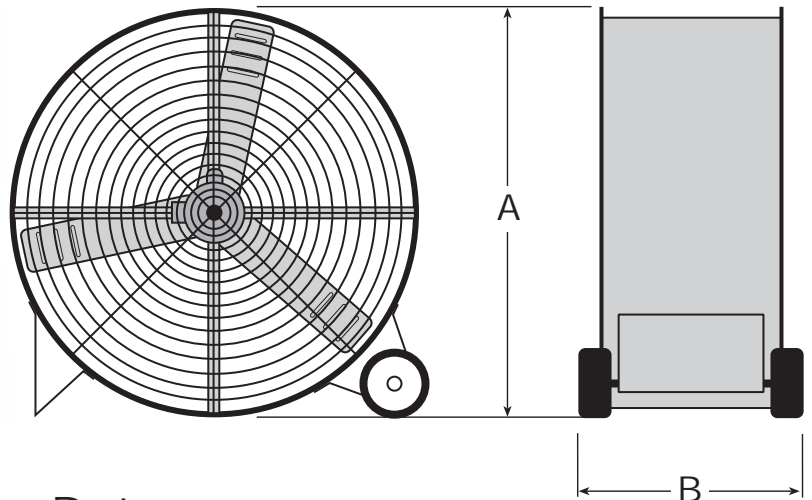

The Model "DMC" is a 30 or 36 inch direct drive, economically priced portable mancooler with no belts or bearings to grease. With high capacity CFM it provides direct cooling of personnel or equipment where extreme temperatures exist, smoke or contaminated air must be controlled.

### Features

- Galvanized construction to resist rust and corrosion.
- Galvanized steel or aluminum propeller.
- 1/4 hp & 1/2 hp direct drive thermally protected motors.
- 8 foot foot cord with switch & plug.
- Epoxy coated OSHA guards.
- Large wheels & handle for ease of movement.



### Dimensional & Performance Data:

MODEL	BLADE DIA.	CFM	RPM	HP	A SIZE	B WIDTH	WT.
30-DMC	30 in.	8,200/6600	825/680	1/4 hp	32 in.	15 in.	60 lbs.
36-DMC	36 in.	10,765	825	1/2 TE	39 in.	18 in.	80 lbs.

Due to continuing research, Future Products reserves the right to change specifications without notice.